

TECHNICAL DATA
DATA SHEET 4983, REV. –

HERMETIC ULTRAFAST RECTIFIER
DUAL - COM. CATHODE / COM. ANODE / DOUBLER

DESCRIPTION: 600 VOLT, 45AMP, 90 NS HERMETIC RECTIFIER IN A TO-259AA PACKAGE.

MAX RATINGS/ELECTRICAL CHARACTERISTIC ALL RATINGS ARE AT $T_A = 25\text{ C}$ UNLESS OTHERWISE SPECIFIED

RATING	SYMBOL	MAX.	UNITS
PEAK INVERSE VOLTAGE (PER LEG)	PIV	600	Volts
MAXIMUM FORWARD VOLTAGE DROP @ $T_A = 25^\circ\text{ C}$ (PER LEG) COMMON CATHODE (P) COMMON ANODE (N) / DOUBLER (D) ($I_f = 22\text{ Amps}$)	V_f	1.7 2.0	Volts
MAXIMUM FORWARD VOLTAGE DROP @ $T_A = 25^\circ\text{ C}$ (PER LEG) COMMON CATHODE (P) COMMON ANODE (N) / DOUBLER (D) ($I_f = 45\text{ Amps}$)	V_f	2.0 2.3	Volts
MAXIMUM FORWARD VOLTAGE DROP @ $T_A = 125^\circ\text{ C}$ (PER LEG) COMMON CATHODE (P) COMMON ANODE (N) / DOUBLER (D) ($I_f = 22\text{ Amps}$)	V_f	1.5 1.8	Volts
MAXIMUM DC OUTPUT CURRENT PER PACKAGE ($T_C = 100^\circ\text{ C}$)	I_o	45	Amps
PEAK SINGLE CYCLE SURGE CURRENT PER LEG $t_p = 8.3\text{ msec}$	I_{FSM}	225	Amps
MAXIMUM REVERSE RECOVERY TIME $I_f = 22\text{A}$, $di/dt = 200\text{A}/\mu\text{s}$, $V_R = 200\text{V}$	t_{rr}	90	nsec
MAXIMUM REVERSE RECOVERY CURRENT $I_f = 22\text{A}$, $di/dt = 200\text{A}/\mu\text{s}$, $V_R = 200\text{V}$	I_{RM}	9	A
MAXIMUM REVERSE RECOVERY CHARGE $I_f = 22\text{A}$, $di/dt = 200\text{A}/\mu\text{s}$, $V_R = 200\text{V}$	Q_{RR}	405	nC
MAXIMUM REVERSE CURRENT I_{rr} @ 600V (PER LEG) @ $T_A = 25^\circ\text{ C}$	I_{rr}	10	μA
MAXIMUM REVERSE CURRENT I_{rr} @ 480V (PER LEG) @ $T_A = 125^\circ\text{ C}$	I_{rr}	1	mA
MAXIMUM THERMAL RESISTANCE (PER LEG)	$R_{\theta JC}$	1.2	$^\circ\text{C}/\text{W}$
MAXIMUM OPERATING AND STORAGE TEMPERATURE RANGE	$T_{op/stg}$	-65 to +150	$^\circ\text{C}$

SENSITRON SEMICONDUCTOR

SHD307901P
SHD307901N
SHD307901D

TECHNICAL DATA DATA SHEET 4983, REV. -

MECHANICAL DIMENSIONS: In Inches / mm

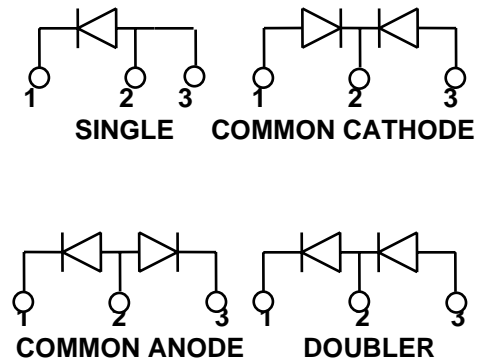
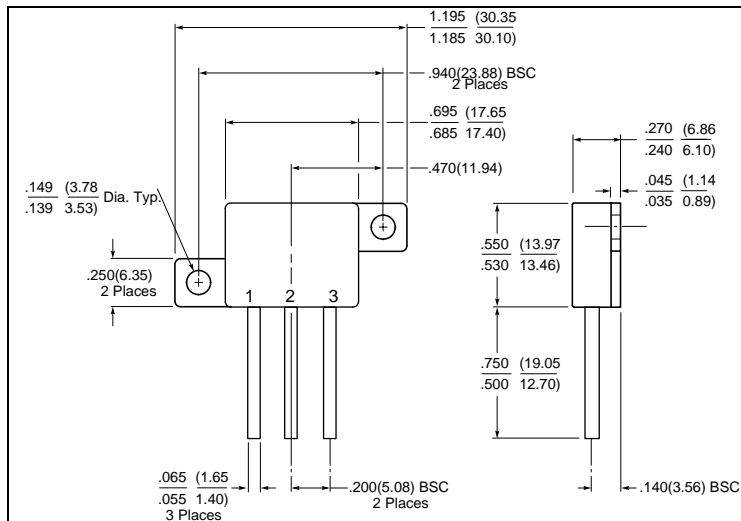

TO-259

PINOUT TABLE

TYPE	PIN 1	PIN 2	PIN 3
SINGLE RECTIFIER	CATHODE	ANODE	ANODE
DUAL RECTIFIER, COMMON CATHODE (P)	ANODE 1	COMMON CATHODE	ANODE 2
DUAL RECTIFIER, COMMON ANODE (N)	CATHODE 1	COMMON ANODE	CATHODE 2
DOUBLER (D)	ANODE	ANODE/CATHODE	CATHODE

Ordering options:

For ceramic eyelets, please order SHDC307901x.

DISCLAIMER:

- 1- The information given herein, including the specifications and dimensions, is subject to change without prior notice to improve product characteristics. Before ordering, purchasers are advised to contact the Sensitron Semiconductor sales department for the latest version of the datasheet(s).
- 2- In cases where extremely high reliability is required (such as use in nuclear power control, aerospace and aviation, traffic equipment, medical equipment, and safety equipment), safety should be ensured by using semiconductor devices that feature assured safety or by means of users' fail-safe precautions or other arrangement.
- 3- In no event shall Sensitron Semiconductor be liable for any damages that may result from an accident or any other cause during operation of the user's units according to the datasheet(s). Sensitron Semiconductor assumes no responsibility for any intellectual property claims or any other problems that may result from applications of information, products or circuits described in the datasheets.
- 4- In no event shall Sensitron Semiconductor be liable for any failure in a semiconductor device or any secondary damage resulting from use at a value exceeding the absolute maximum rating.
- 5- No license is granted by the datasheet(s) under any patents or other rights of any third party or Sensitron Semiconductor.
- 6- The datasheet(s) may not be reproduced or duplicated, in any form, in whole or part, without the expressed written permission of Sensitron Semiconductor.
- 7- The products (technologies) described in the datasheet(s) are not to be provided to any party whose purpose in their application will hinder maintenance of international peace and safety nor are they to be applied to that purpose by their direct purchasers or any third party. When exporting these products (technologies), the necessary procedures are to be taken in accordance with related laws and regulations.