

TECHNICAL DATA
DATA SHEET 592, REV. -

Three-Phase MOSFET/IGBT Bridge Driver

Absolute Maximum Rating

Absolute Maximum Rating indicate sustained limits beyond which damage to the device may occur. All voltage parameters are absolute voltages referenced to COM. The thermal resistance is specified under board mounted and still air conditions.

PARAMETER	SYMBOL	MIN	TYP	MAX	UNIT
High Side Floating Supply Voltage	$V_{B1,2,3}$	-0.3	-	625	V
High Side Floating Supply Voltage	$V_{S1,2,3}$	$V_{B1,2,3} - 25$	-	$V_{B1,2,3} + 0.3$	V
Supply Voltage	V_{CC}	-0.3	-	25	V
Logic Ground	V_{SS}	- 0.3	-	$V_{CC} + 0.3$	V
Logic Input Voltage (\overline{HIN} , \overline{LIN} , ITRIP $\overline{FLT-CLR}$, SD)	V_{IN}	$V_{SS} - 0.3$	-	$V_{CC} + 0.3$	V
Op-Amp Input Voltage	V_{IN-Amp}	$V_{SS} - 0.3$	-	$V_{CC} + 0.3$	V
FAULT Output Voltage	V_{FLT}	$V_{SS} - 0.3$	-	$V_{CC} + 0.3$	V
Thermal Resistance	R_{thjA}		-	80	$^{\circ}C/W$
Junction Temperature	T_j	-55	-	150	$^{\circ}C$
Lead Soldering Temperature, 10 sec	T_L	-	-	250	$^{\circ}C$

Recommended Operating Conditions

PARAMETER	SYMBOL	MIN	TYP	MAX	UNIT
High Side Floating Supply Voltage	$V_{B1,2,3}$	$V_{S1,2,3} + 10$	-	$V_{S1,2,3} + 20$	V
High Side Floating Supply Voltage	$V_{S1,2,3}$	-5	-	300	V
Supply Voltage	V_{CC}	10	-	20	V
Logic Ground	V_{SS}	- 5	-	5	V
Logic Input Voltage (\overline{HIN} , \overline{LIN} , ITRIP $\overline{FLT-CLR}$, SD)	V_{IN}	V_{SS}	-	$V_{SS} + 5$	V
Op-Amp Input Voltage	V_{IN-Amp}	V_{SS}	-	$V_{SS} + 5$	V
FAULT Output Voltage	V_{FLT}	V_{SS}	-	V_{CC}	V

Dynamic Characteristics

$V_{CC}=V_{BS1,2,3} = 15V, V_{S1,2,3} = V_{SS}, C_L = 1 \text{ nF}$

PARAMETER	TEST CONDITIONS	SYMBOL	MIN	TYP	MAX	UNIT
Turn-On Propagation Delay	$V_{IN} = 0 \text{ \& } 5V$ $V_{S1,2,3} = 0 \text{ to } 300V$	t_{on}	-	700	-	nsec
Turn-Off Propagation Delay		t_{off}	-	700	-	nsec
Turn-On Rise Time		t_r	-	75	-	nsec
Turn-Off Fall Time		t_f	-	35	-	nsec
SD to Output Shutdown Propagation Delay	$V_{IN}, V_{ITRIP} = 0V,$ $V_{SD} = 0 \text{ \& } 5V$	t_{sd}	-	700	-	nsec
ITRIP to Output Shutdown Propagation Delay	$V_{IN} = 0V,$ $V_{ITRIP} = 0 \text{ \& } 5V$	t_{itrip}	-	700	-	nsec
ITRIP Blanking Time	$V_{ITRIP} = 1V$	t_{bl}	-	400	-	nsec
ITRIP to $\overline{\text{FAULT}}$ Shutdown Propagation Delay	$V_{IN} = 0V,$ $V_{ITRIP} = 0 \text{ \& } 5V$	t_{flt}	-	500	-	nsec
Input Filter Time ($\overline{\text{HIN}}, \overline{\text{LIN}}, \text{ \& } \text{SD}$)	$V_{IN} = 0 \text{ \& } 5V$	t_{fil}		310		nsec
Deadtime, LS Turn-Off to HS Turn-on & HS Turn-Off to LS Turn-On	$V_{IN} = 0 \text{ \& } 5V$	DT	-	200	-	nsec

Static Characteristics

$V_{CC}=V_{BS1,2,3} = 15V, V_{S1,2,3} = V_{SS}$

PARAMETER	TEST CONDITIONS	SYMBOL	MIN	TYP	MAX	UNIT
Logic "0" Input Voltage (Output = LO)		V_{IH}	2.2	-	-	V
Logic "1" Input Voltage (Output = HI)		V_{IL}	-	-	0.8	V
Logic "0" Fault Clear Input Voltage		$V_{FCLR,IH}$	2.2	-	-	V
Logic "1" Fault Clear Input Voltage		$V_{FCLR,IL}$	-	-	0.8	V
SD Input Positive Going Threshold		$V_{SD,TH+}$	-	1.8	-	V
SD Input Negative Going Threshold		$V_{SD,TH-}$	-	1.5	-	V
ITRIP Input Positive Going Threshold		$V_{IT,TH+}$	-	0.485	-	V
ITRIP Input Negative Going Threshold		$V_{IT,TH-}$	-	0.400	-	V
Quiescent V_{CC} Supply Current	$V_{IN} = 0V, \text{ or } 5V$	I_{QCC}	-	4	-	mA
Supply Under Voltage Positive Going Threshold		V_{CCIUV+} $V_{BSIUUV+}$	-	10.4	-	V
Supply Under Voltage Negative Going Threshold		V_{CCIUV-} $V_{BSIUUV-}$	-	9.4	-	V
Output High Short Circuit Pulsed Current	$V_{OUT} = 0V,$ $V_{IN} = 0V,$ $t_p < 10 \mu\text{sec}$	I_{O+}	200	250	-	mA
Output Low Short Circuit Pulsed Current	$V_{OUT} = 0V,$ $V_{IN} = 0V,$ $t_p < 10 \mu\text{sec}$	I_{O-}	420	500	-	mA

Schematic Diagram

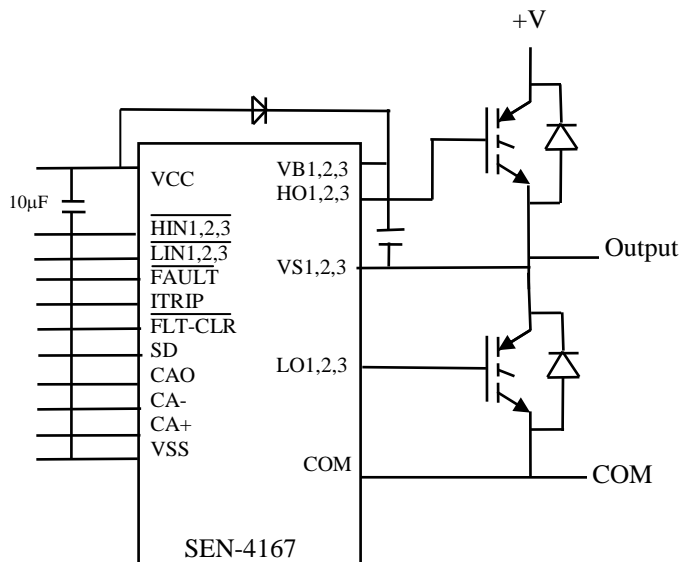

Package Layout:

