

TECHNICAL DATA
DATA SHEET 4775, REV. A**HERMETIC POWER SCHOTTKY RECTIFIER**
Low Forward Voltage**Applications:**

- Switching Power Supply
- Converters
- Free-Wheeling Diodes
- Polarity Protection Diode

Features:

- Soft Reverse Recovery at Low and High Temperature
- Low Forward Voltage Drop
- Low Power Loss, High Efficiency
- High Surge Capacity
- Guard Ring for Enhanced Durability and Long Term Reliability
- Guaranteed Reverse Avalanche Characteristics

Maximum Ratings:

Characteristics	Symbol	Condition	Max.	Units
Peak Inverse Voltage	V_{RWM}	-	100	V
Max. Average Forward Current	$I_{F(AV)}$	50% duty cycle, rectangular wave form (Single/Doubler)	45	A
Max. Average Forward Current	$I_{F(AV)}$	50% duty cycle, rectangular wave form (Common Cathode/Common Anode)	45	A
Max. Peak One Cycle Non-Repetitive Surge Current	I_{FSM}	8.3 ms, half Sine wave (per leg)	200	A
Max. Thermal Resistance	$R_{\theta JC}$	(Per leg)	1.15	°C/W
Max. Junction Temperature	T_J	-	-65 to +175	°C
Max. Storage Temperature	T_{stg}	-	-65 to +175	°C

Electrical Characteristics:

Characteristics	Symbol	Condition	Max.	Units
Max. Forward Voltage Drop	V_{F1}	@ 45A, Pulse, $T_J = 25\text{ °C}$ (per leg)	1.10	V
	V_{F2}	@ 45A, Pulse, $T_J = 125\text{ °C}$ (per leg)	0.92	V
Max. Reverse Current	I_{R1}	@ $V_R = 100V$, Pulse, $T_J = 25\text{ °C}$ (per leg)	1.0	μA
	I_{R2}	@ $V_R = 100V$, Pulse, $T_J = 125\text{ °C}$ (per leg)	24	mA
Max. Junction Capacitance	C_T	@ $V_R = 5V$, $T_C = 25\text{ °C}$ $f_{SIG} = 1MHz$, $V_{SIG} = 50mV$ (p-p) (per leg)	1500	pF

TECHNICAL DATA
DATA SHEET 4775, REV. A

Mechanical Dimensions: In Inches / mm

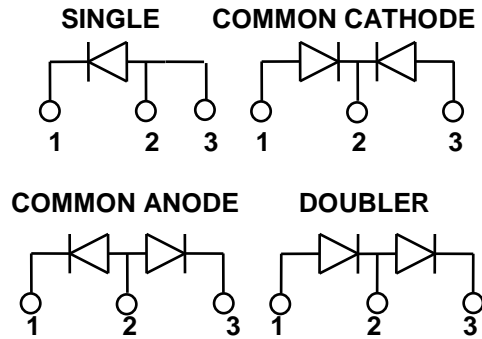
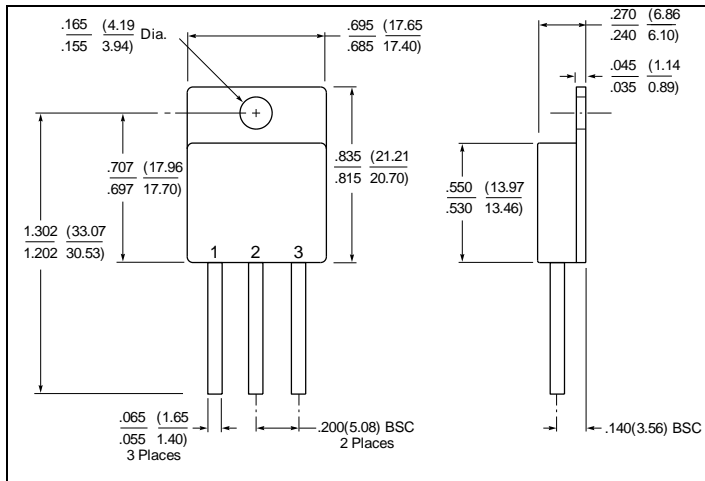

TO-258

PINOUT TABLE

TYPE	PIN 1	PIN 2	PIN 3
SINGLE RECTIFIER	CATHODE	ANODE	ANODE
DUAL RECTIFIER, COMMON CATHODE (P)	ANODE 1	COMMON CATHODE	ANODE 2
DUAL RECTIFIER, COMMON ANODE (N)	CATHODE 1	COMMON ANODE	CATHODE 2
DUAL RECTIFIER, DOUBLER (D)	ANODE	CATHODE/ANODE	CATHODE

Note: The V_f curves shown are for the SD200SC100 un-packaged die only.

Typical Forward Characteristics

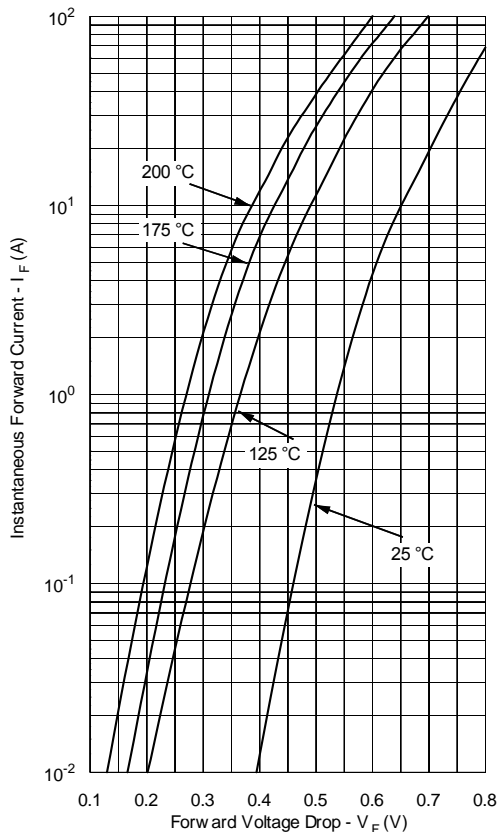

Typical Reverse Characteristics

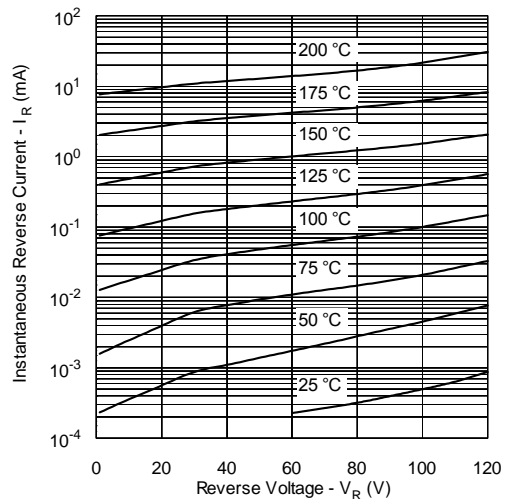

Typical Junction Capacitance

