

TECHNICAL DATA
DATA SHEET 5285, Rev A

POSITIVE ADJUSTABLE 3.0 AMP REGULATOR

FEATURES:

- ISOLATED HERMETIC PACKAGE (TO-257)
- SIMILAR to INDUSTRY TYPE LM150A
- Add Suffix "S" for S-100 Screening

MAXIMUM RATINGS

Parameter	Conditions	Typical	Limit	Units
Input to Output Voltage Differential			35	Vdc
Storage Temperature Range			-65 to +150	°C
Power Dissipation (P _D)			Internally Limited	W
Maximum Thermal Resistance Junction to Case (θ _{JC})			4.2	°C/W
Operating Junction Temperature Range (T _J)			-55 to +150	°C

ELECTRICAL CHARACTERISTICS -55°C ≤ T_a ≤ 125°C unless otherwise specified

Parameter	Conditions	Min	Typ.	Limit	Units
Reference Voltage	I _{OUT} = 10mA, T _a = 25°C 3.0V ≤ V _{IN} - V _{OUT} ≤ 35V, 10mA ≤ I _{OUT} ≤ 3.0A, P ≤ 30W T _A = +25°C	1.238 1.225		1.262 1.270	V
Line Regulation	3.0V ≤ V _{IN} - V _{OUT} ≤ 35V, I _{OUT} = 10mA, T _J = 25°C 3.0V ≤ V _{IN} - V _{OUT} ≤ 35V, I _{OUT} = 10mA			.01 .05	%/V
Load Regulation	10mA ≤ I _{OUT} ≤ 3.0A 10mA ≤ I _{OUT} ≤ 3.0A, T _J = +25°C			1 0.3	% %
Adjust Pin Current				100	μA
Adjust Pin Current Change	10mA ≤ I _{OUT} ≤ 3.0A 3.0V ≤ V _{IN} - V _{OUT} ≤ 35V			5	μA
Minimum Load Current	V _{IN} - V _{OUT} = 35V			5.0	mA
Current Limit	V _{IN} - V _{OUT} ≤ 10V V _{IN} - V _{OUT} = 30V	3.0 0.3			A A
Ripple Rejection Ratio	V _{OUT} = 10V, f = 120Hz, C _{ADJ} = 10μF	66			dB
Thermal Regulation	20 ms pulse, T _A = 25°			0.01	%/W

TECHNICAL DATA
DATA SHEET 5285, Rev A

MECHANICAL DIMENSIONS in inches & mm

TO-257

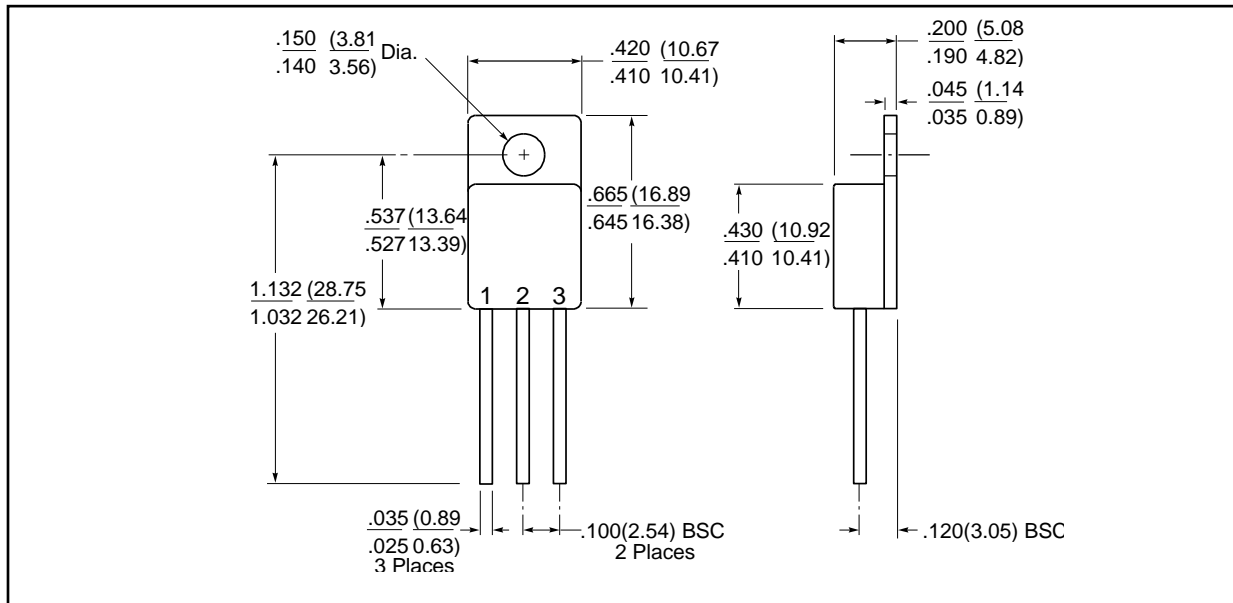

PINOUT TABLE

TYPE	PIN 1	PIN 2	PIN 3	TAB
TO – 257 3.0A Adjustable Regulator	ADJUST	V _{OUT}	V _{IN}	ISOLATED

DISCLAIMER:

- 1- The information given herein, including the specifications and dimensions, is subject to change without prior notice to improve product characteristics. Before ordering, purchasers are advised to contact the Sensitron Semiconductor sales department for the latest version of the datasheet(s).
- 2- In cases where extremely high reliability is required (such as use in nuclear power control, aerospace and aviation, traffic equipment, medical equipment, and safety equipment), safety should be ensured by using semiconductor devices that feature assured safety or by means of users' fail-safe precautions or other arrangement.
- 3- In no event shall Sensitron Semiconductor be liable for any damages that may result from an accident or any other cause during operation of the user's units according to the datasheet(s). Sensitron Semiconductor assumes no responsibility for any intellectual property claims or any other problems that may result from applications of information, products or circuits described in the datasheets.
- 4- In no event shall Sensitron Semiconductor be liable for any failure in a semiconductor device or any secondary damage resulting from use at a value exceeding the absolute maximum rating.
- 5- No license is granted by the datasheet(s) under any patents or other rights of any third party or Sensitron Semiconductor.
- 6- The datasheet(s) may not be reproduced or duplicated, in any form, in whole or part, without the expressed written permission of Sensitron Semiconductor.
- 7- The products (technologies) described in the datasheet(s) are not to be provided to any party whose purpose in their application will hinder maintenance of international peace and safety nor are they to be applied to that purpose by their direct purchasers or any third party. When exporting these products (technologies), the necessary procedures are to be taken in accordance with related laws and regulations.